

PWB Calibration Software for Encoders

(GUI Version 2.3)



User Manual AS25/50 BiSS/SSI/SPI

1 Introduction

Thank you for purchasing a product from PWB Encoders!

Our Mini-Encoders, Encoder Wheels, Encoder Strips and customized Motor-Encoder-Assemblies are used million fold in multiple industries and fields of application.

PWB encoders GmbH has always been very customer-oriented, and this ensures our worldwide growth. Our Marketing acts as interface between customer, development, distribution and production, and thus presents ideas for many innovations.

This user manual explain how to use the calibration tool AS25/50 BiSS/SSI/SPI. This calibration tool is needed to calibrate your encoder after mounting in your application, so that the best operating stability can be reached.

For calibration you need an encoder, interface type (see matrix 3.1) PWBxC and a USB cable, USB type A to USB type mini-B.

1.1 Description Encoder AS25/50

The AS 25/50 is a high-resolution, multi-functional encoder. It offers a variety of common encoder interfaces. The AS 25/50 generates simultaneously position data as well as speed data. Thus, the encoder is ideal for positioning and rotation speed control. The AS 25/50 is based on radial Hall sensing of a two track magnetic wheel by using the nonius principle. The differential sensing offers the advantage of effectively suppressing homogenous magnetic interferences. This is the reason why static fields don't have a significant influence on output signals.

1.2 Features

- Singleturn encoder
- Magnetic sensing
- port output (absolute + incremental simultaneously)
- Interface:
 - SSI (synchron serial interface) (up to 18 Bit)
 - BiSS ® (bidirectional serial synchron) (up to 18 Bit)
 - SPI (serial peripheral interface) (up to 18 Bit)
 - ABI (incremental interface) (up to 65.536 cpr)
 - UVW (commutation signals) (up to 16 pole pairs)
 - Sin/Cos (analog interface) (up to 64 periods)
- High protection class
- Compact size
- Bearing free
- High shock and vibration resistant
- Operating temperature: -20°C to +85°C
- Compliant EU-directive 2011/65/EU (RoHS)

1.3 Applications

- Motor feedback
- BLDC motor commutation
- Hollow shaft
- Multi-axis measurement systems





2 Index

- 1 Introduction 2**
- 1.1 Description Encoder AS25/50 2
- 1.2 Features 2
- 1.3 Applications 2
- 2 Index 3**
- 3 First Steps 4**
- 3.1 Software / Encoder Matrix 4
- 3.2 Download Software 4
- 3.3 Direct Links 4
- 3.4 System Requirements 5
- 3.5 Installation of Software 5
- 3.6 Connect Box to PC 6
- 4 Automatic Calibration 7**
- 4.1 Automatic calibration Step 1 7
- 4.2 Automatic calibration Step 2 7
- 4.3 Automatic calibration Step 3 7
- 5 Manual Calibration 8**
- 5.1 Define manual calibration values 8
- 5.2 Manual calibration Step 1 9
- 5.3 Manual calibration Step 2 9
- 5.4 Manual calibration Step 3 10
- 5.5 Manual calibration Step 4 10
- 5.6 Troubleshooting 11
- 5.7 Successful calibration / Graph Display 11
- 6 Position / Status Tab 12**
- 7 Backup 12**
- 8 Save settings to Encoder – Store Setup 12**
- 9 Contact – Customer Service 13**
- 10 IMPORTANT NOTICE 13**

3 First Steps

3.1 Software / Encoder Matrix

For our different types of encoders different programming boxes and software are needed for a successful calibration process. Take a look at the following matrix which shows the dependencies.

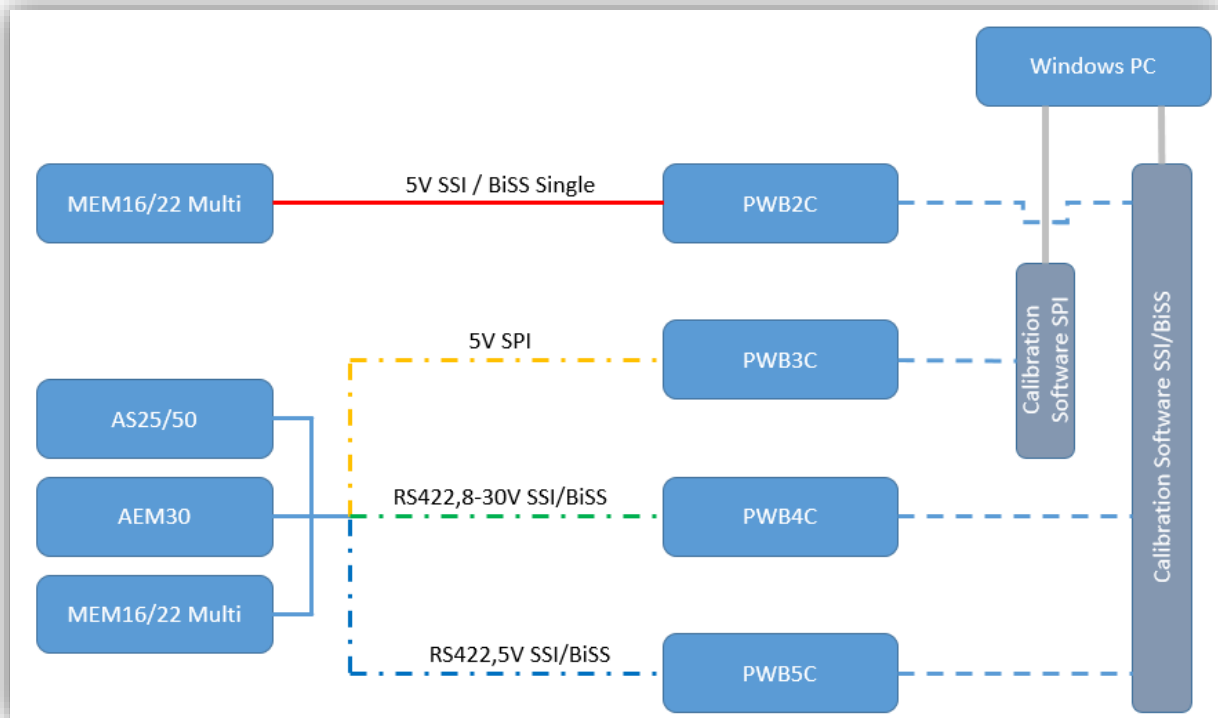

3.2 Download Software

There are two software installation-packages available:

- One package including LabView runtime engine (LV RTE) 11.0 for operating systems without LabView runtime engine already installed. (Size 124MB)
- One package without LabView runtime engine. (Size 9MB)

Download the software here: <http://www.pwb-encoders.com/en/magnetic-encoders/as-25>

3.3 Direct Links

[Calibration-Software for AS25/AS50 SPI no RTE Size: 9MB](#)

[Calibration-Software for AS25/AS50 SPI with RTE Size: 124MB](#)

[Calibration-Software for AS25/AS50 BiSS/SSI no RTE Size: 9MB](#)

[Calibration-Software for AS25/AS50 BiSS/SSI with RTE Size: 124MB](#)

3.4 System Requirements

- Operation System Microsoft Windows 7 or higher
- Processor 1 GHz or higher and 32-Bit (x86)- or 64-Bit (x64)-Architecture
- At least 2 GB RAM, if using 32-Bit-Version, 2 GB for 64-Bit-Version
- Minimum 500 MB free Disk Space
- One free USB Port

3.5 Installation of Software

1. Install the software by starting „Setup.exe“. Follow installation routine. Older versions will be overwritten.
2. Install USB Driver you'll find in the extracted folder.

Install USB_PWB2C_driver_ftdi21200 for use with PWB2C Interface
Install USB_PWB3C_driver_ftdi21200 for use with PWB3C Interface
Install USB_PWB4C_driver_25000 for use with PWB4C Interface
Install USB_PWB5C_driver_27600 for use with PWB5C Interface

3.6 Connect Box to PC

Connect the Encoder to the Interface PWBxC and the box to your PC (USB3.0 cable required) maximum USB cable length 2 meters. For longer distances increase the length of the SUB-D cable (maximum 10 meters).



4 Automatic Calibration

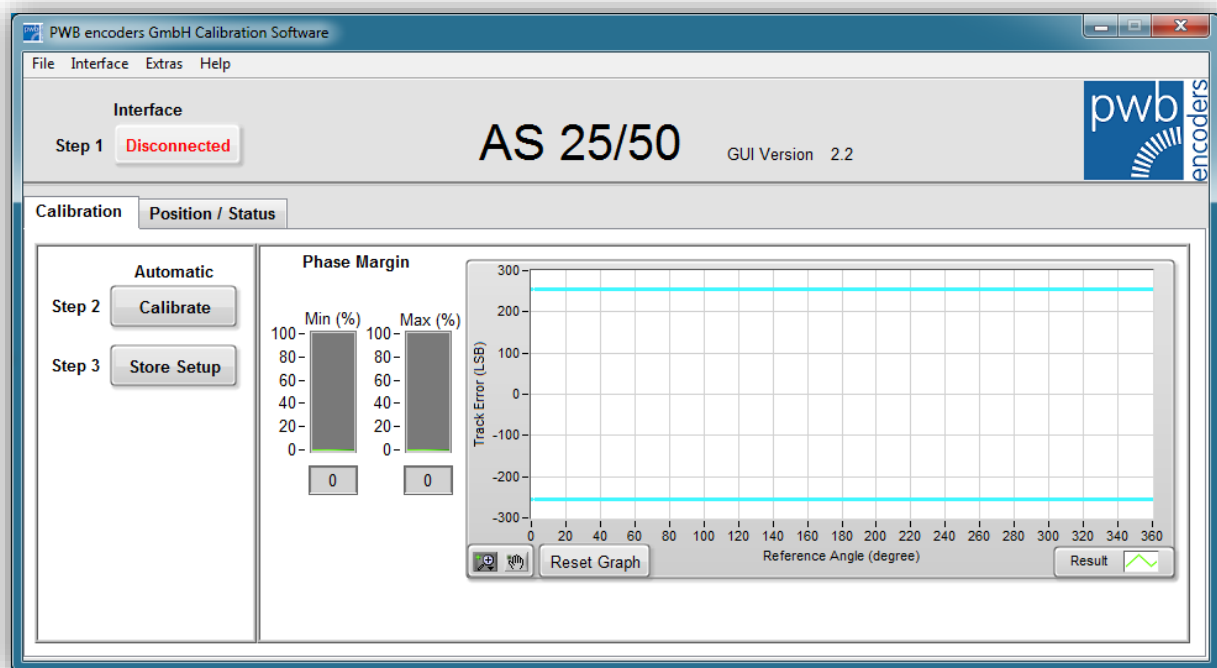

4.1 Automatic calibration Step 1

After clicking the button „**Disconnected**“ (Step 1) the software will connect with the interface and the encoder. The button switch to “**Connected**” when all components successfully connected.

4.2 Automatic calibration Step 2

Start calibration of the encoder with magnetic wheel. Use button “**Calibrate**”

For AS25 use a magnetic wheel with an outer diameter of 24,5mm, for AS50 use a magnetic wheel with an outer diameter of 50,7mm. Changing the magnetic wheels AS25 to AS50 and backwards is not possible. The magnetic wheel has to rotate continuous at about **200rpm**. If it moves to fast, to slow or stops, an error will be displayed. In that case restart calibration.

4.3 Automatic calibration Step 3

Click on “**Store Setup**” to save calibration results to encoder. (Without saving calibration results will be lost.)

5 Manual Calibration

(Manual calibration is needed for applications like sluices or other not full turning applications)

After clicking the button „**Disconnected**“ (Step 1) the software will connect with the interface and the encoder. The Button switch to „**Connected**“ when all components successfully connected.

After that, select „**Extras**“ from the menu bar and click „**Manual Calibration**“ (or CTRL+ M), now, calibration wizard window will open.

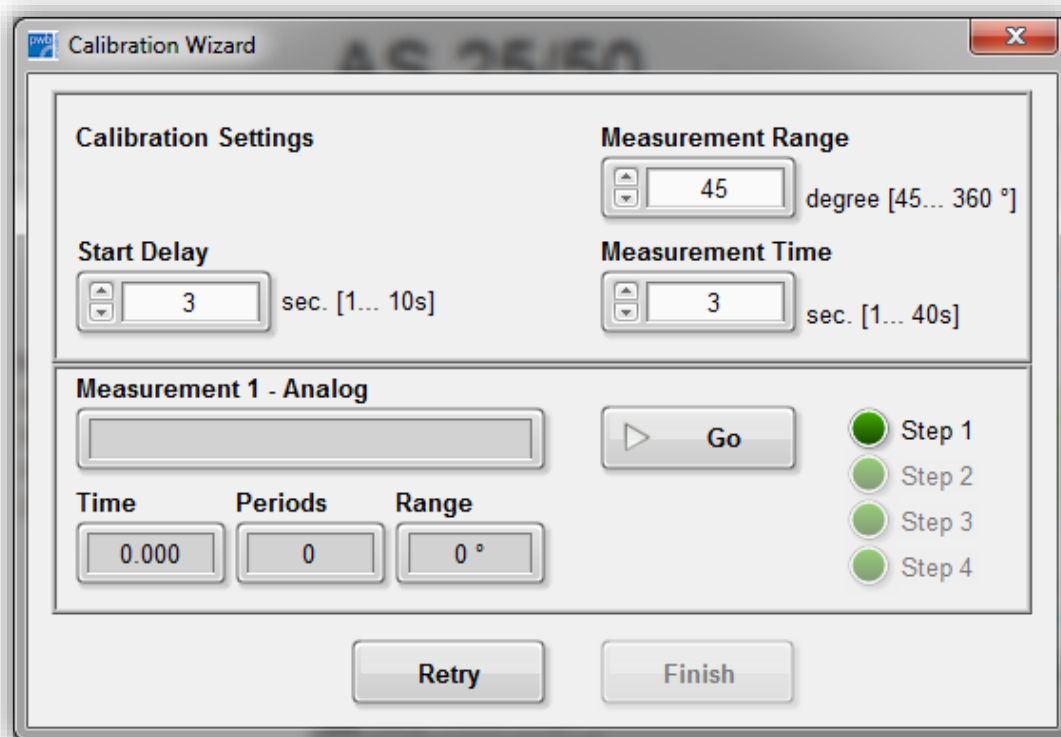

5.1 Define manual calibration values

Following values can / have to be modified:

- **Start Delay**
Time until calibration starts
- **Measurement Range (Angle)**
Adjust the angle of your application. Select an angle which is 10° smaller than your real movement to ensure that the calibration can be finished.
- **Measurement Time**
Enter the time needed for the calibration process.

User Manual AS25/50 BiSS/SSI/SPI

5.2 Manual calibration Step 1

Click „Go“ and the delay time starts running. After that time calibration process will start and the progress bar appears.

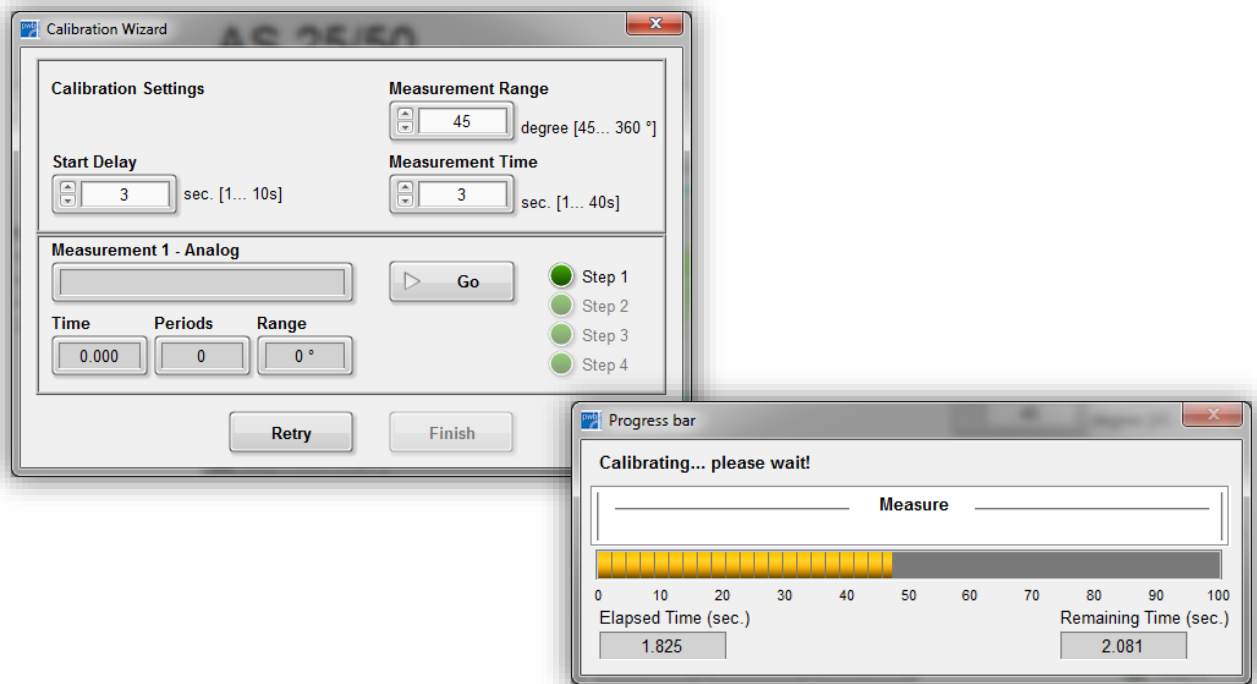

Now immediately start turning the magnetic wheel **in one direction** (in your application) within the time you've entered. When the complete angle is reached and time is finished, the green beacon switch to Step 2.

5.3 Manual calibration Step 2

Click on „Go“ again, now turn the magnetic wheel the complete angle **in the opposite direction**. The green beacon switch to Step 3.

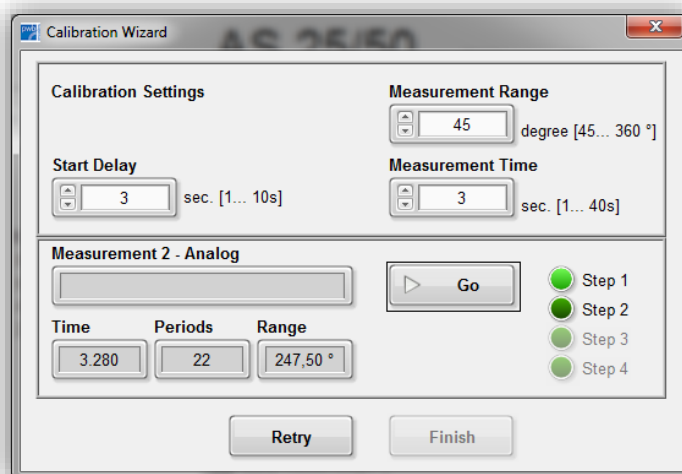

User Manual AS25/50 BiSS/SSI/SPI

5.4 Manual calibration Step 3

Click on „Go“ on more time and turn again (same direction like Step 1). The green beacon switch to Step 4.

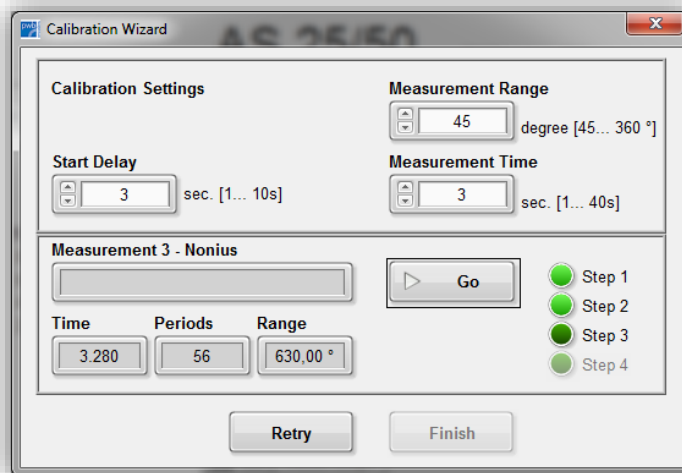

5.5 Manual calibration Step 4

Click on „Go“ one last time and turn in the opposite direction again (like Step 2)
If this Step was successful, please click the “Finish” button.

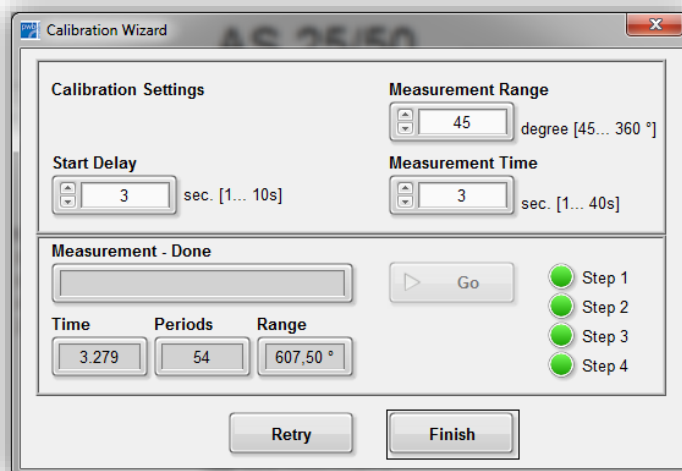

User Manual AS25/50 BiSS/SSI/SPI

5.6 Troubleshooting

When the real rotation was smaller than the entered value, the “Range” value appears yellow. Please select a smaller angle and click “**Retry**” to start calibration again for best results (back to Step1).

Explanation: The program expect that the entered angle would be reached. If not, the yellow field appears.

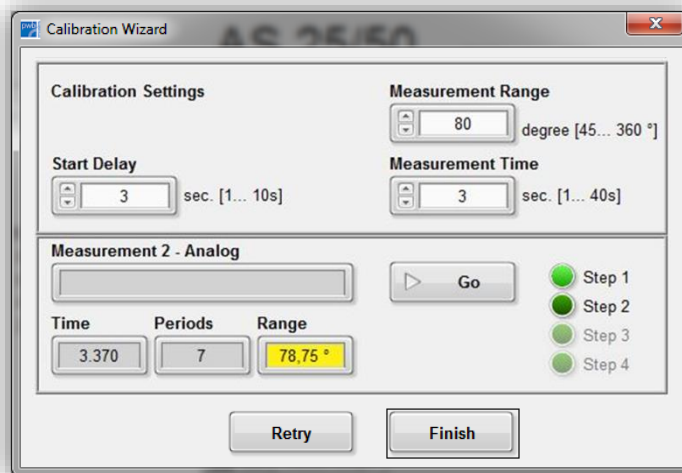

5.7 Successful calibration / Graph Display

If all manual measurements finished successful, the traveled angle area will be displayed and the quality of the signal is displayed as a graph. You can inspect the graph with the displayed tools, change line style and also export data to clipboard and Excel.



6 Position / Status Tab

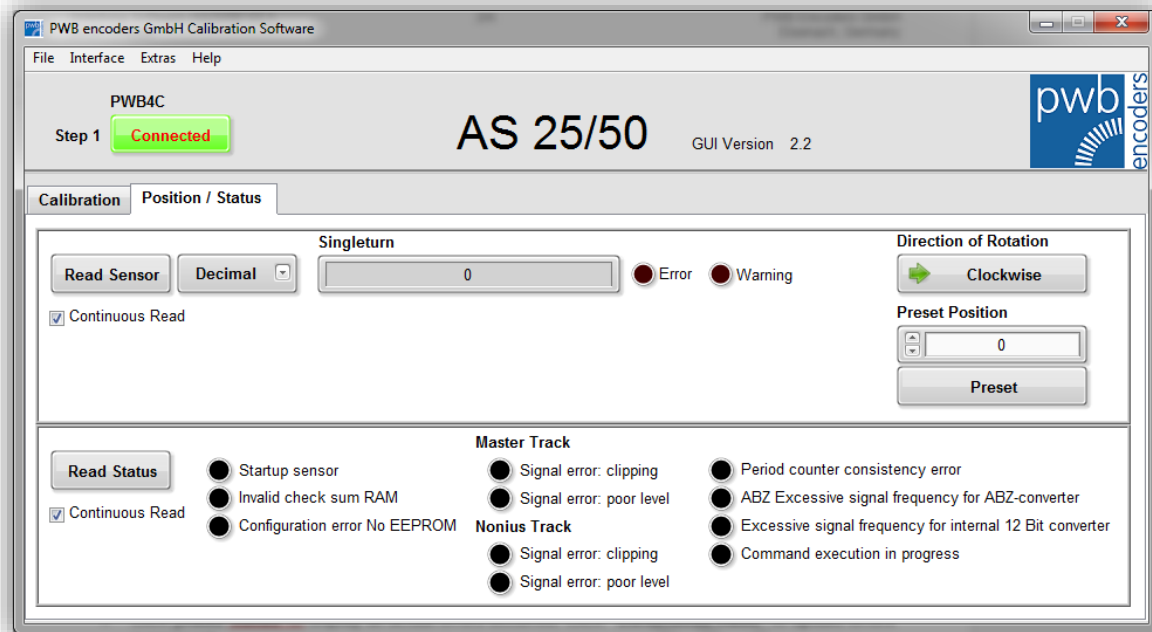

- By clicking „**Read Sensor**“ actual values can be displayed.
- To display the “Singleturn” value in different number systems, select your desired from the dropdown “**Decimal**” button on the left
- By selecting “**Continuous read**” you can switch between permanent refreshing and one time updating of the singleturn value.
- With the button „**Direction of Rotation**“ you can switch between **Clockwise (CW)** and **Counterclockwise (CCW)**.
 - **CW**: Increasing value when turning clockwise, see shaft (mounting side)
 - **CCW**: Decreasing value when turning counterclockwise, see shaft (mounting side)
- When changing the direction of rotation, the displayed position value changes to its complementary value.
- With „**Set to Zero**“ the singleturn value set to 0 at the actual position. You have to save this modification via Calibration Step 3.
- Click „**Read Status**“ to display all actual errors occurred. Click “**Continuous Read**” to update errors permanent.

7 Backup

By clicking Extras → “**Generate Report**” or press CTRL.+ F12 you can save all actual values into a file. For problems with the calibration, you can send this file to PWB for analysis

8 Save settings to Encoder – Store Setup

If all values modified, save them to the encoders EEPROM via Step 3 “**Store Setup**” after that the program will close connection to the encoder and the interface.

9 Contact – Customer Service

For any questions or support please feel free to contact us!

PWB encoders GmbH
Am Goldberg 2
D-99817 Eisenach
Germany
Phone: +49 3691 72580-0
Fax: +49 3691 72580-29
Mail: info@pwb-encoders.com

杰德國際股份有限公司
新北市板橋區雙十路二段6~10號7F
TEL:02-22555711 FAX:02-22537636
Email: kaltec@kaltec.com.tw

10 IMPORTANT NOTICE

The guarantee will be voided by misuse, accident, modification, unsuitable physical or operating environment, operation in other than the specified operating environment, or failure caused by a product for which PWB encoders GmbH is not responsible.

PWB encoders GmbH reserves the right to make corrections, modifications, enhancements, improvements, and other changes to its products and services also datasheets at any time.